

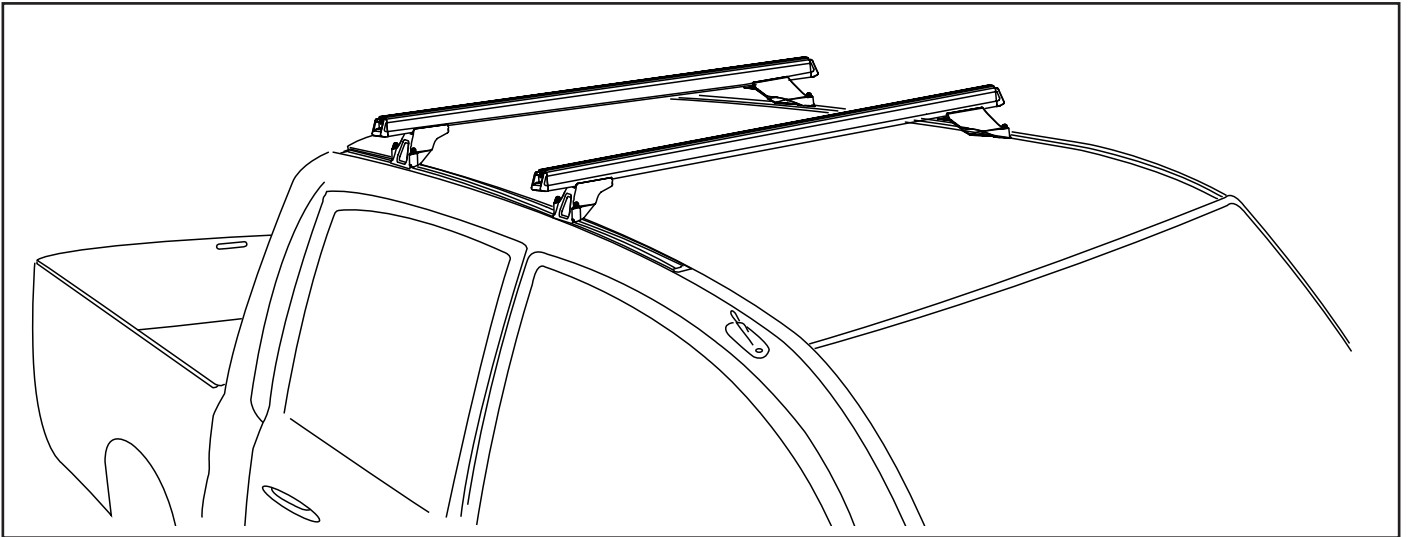

RHINO-RACK

RTS509 Rhino Heavy Duty Track Mount System - MITSUBISHI TRITON ML

Important: Please read these instructions carefully prior to installation.
Please refer to your fitting instruction to ensure that the roof racks are installed in the correct locations.
Check the contents of kit before commencing fitment and report any discrepancies.
Place these instructions in the vehicle's glove box after installation is complete.



Care Instruction: Wash vehicle roof especially the mounting points prior to installation.

Important Information

Maximum carrying capacity: 100kg

Recommendations:

It is essential that all bolt connections be checked after driving a short distance when you first install your cross bars. Bolt connections should be checked again at regular intervals (probably once a week is enough, depending on road conditions, usage, loads and distances travelled). You should also check the cross bars each time they are re-fitted.

Make sure to fasten your load securely. Please ensure that all loads are evenly distributed and that the centre of gravity is kept as low as possible.

Use only non-stretch fastening ropes or straps.

Sensitivity to cross winds, behaviour in curves and braking.

The handling characteristics of the vehicle, changes when you transport a load on the roof. For safety reasons, we recommend you exercise extreme care when transporting wind-resisting loads; special consideration must be taken into account when braking.

Please remove cross bars when putting vehicle through an automatic car wash.

Load Ratings:

Maximum permissible load is 100kg per pair of cross bars (include the weight of the cross bars, 5kg). When cross bars are to be used in off-road conditions, please build a safety factor of 1.5 into this load limit. Although the cross bars are tested and approved to AS1235-2000, Australian road conditions can be much more rigorous. However, increasing the number of cross bars does not increase the vehicles maximum permissible roof loading.

Note for Dealers and Fitters:

It is your responsibility to ensure instructions are given to the end user or client.

Rhino-Rack
3 Pike Street, Rydalmere,
NSW 2116, Australia.
(Ph) (02) 9638 4744
(Fax) (02) 9638 4822

Document No: RR-153
Prepared By: Andy Wana
Authorised By: Andy Wana

Issue No: 03
Issue Date: 21/06/2013

These instructions remain the property of Rhino Rack Australia Pty. Ltd. and may not be used or changed for any other purpose than intended.



Rhino Heavy Duty - MITSUBISHI Triton ML

Parts List

Item	Component Name	Qty	Part No.
1	Track End Cap (Left)	2	C393
2	Triton Track 1150mm	1 Pair	C604
3	Track End Cap (Right)	2	C394
4	Heavy Duty Rubber Buffer 1375mm	2	R004
5	Heavy Duty Cross Bar End Cap	4	M002
6	Heavy Duty Cross Bar 1375mm	2	A020
7	M6 x 35mm Security Screw	8	B092
8	M10 Channel Nut	4	N024
9	Swivel Adaptor	2	M292
10	M6 Spring Washer	8	W004
11	M6 x 12.5mm Flat Washer	8	W003
12	RLTF Heavy Duty Leg	4	M010
13	M6 x 21.43mm x 4.40mm Brass Nut	8	N009
14	M10 x 38mm Flat Washer	4	W022
15	M10 Internal Shakeproof Washer	4	W021
16	M10 x 25mm Hex Bolt	4	B071
17	M10 x 35mm Hex Bolt	4	B079
18	5mm Rivet	12	H008
19	5mm Security Allen Key	1	SECKEY-S
20	Fitting Instruction	1	RR-153

Tools Required:

Pneumatic or Concertina rivet gun.	Silastic Sealer/Butyl Mastic.
Marking pen.	5mm Security Allen key, provided in kit
Power or Cordless drill.	5/8 or 16mm spanner.
5mm drill with depth stop.	Measuring tape.
Vacuum cleaner.	Hacksaw.
Cold galvanizing solution & brush.	Philips head screwdriver.
	Flat head screwdriver.

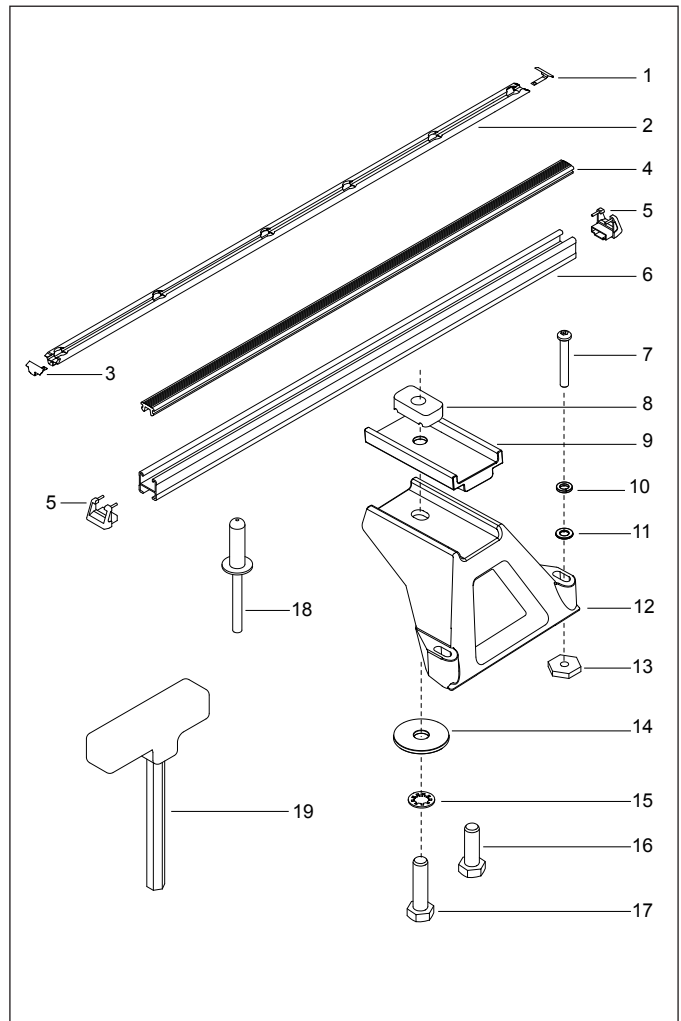

1

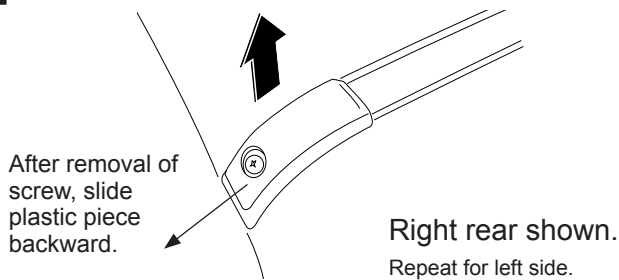

Remove rear plastic trim.

Use a philips head screwdriver to remove screw holding the plastic trim at the rear. This will facilitate removal of the long roof channel trim.

2 Completely remove roof channel trim.

Lift edge of rubber trim to expose plastic clips. A flat head screwdriver will be needed to depress the clips to unhook them from the roof trim. As shown, twist a flat head screwdriver to remove the clips off the rib.



LIFT TRIM FROM OUTSIDE EDGE OF ROOF.

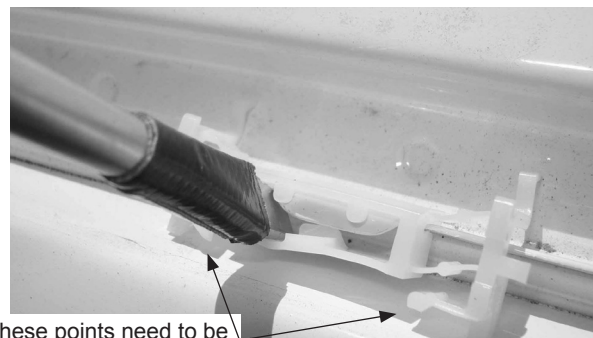

These points need to be depressed for removal.



Rhino Heavy Duty - MITSUBISHI Triton ML

3

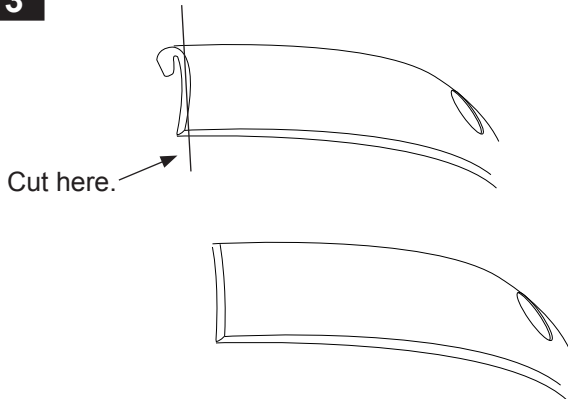

Trim existing Cap.

Use a pair of scissors to cut a minimal amount off the existing roof trim cap to square it up.

4

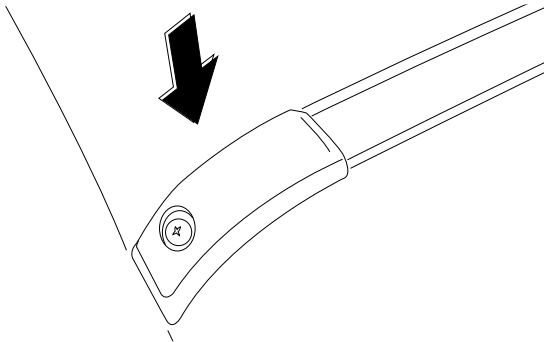

Re-fit rear plastic trim.

Use a philips head screwdriver to attach screw holding the plastic trim at the rear.

5

Fit End Cap.

Place rear end cap into rear of track extrusion.

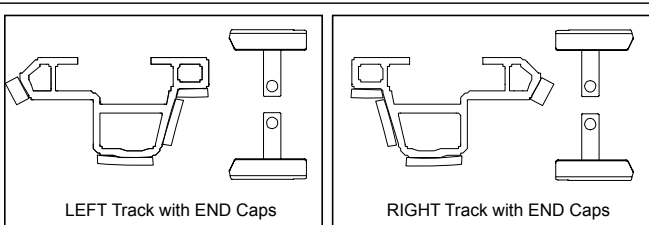

Tracks viewed from rear of vehicle.

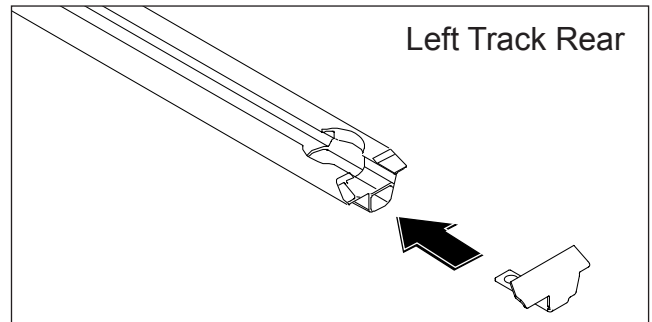

TOP VIEW

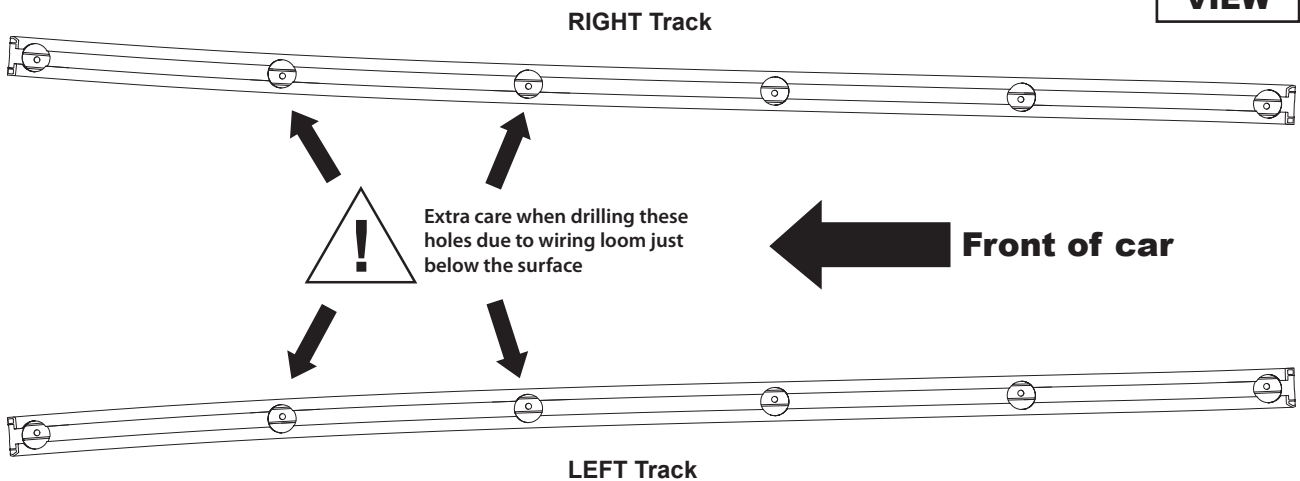



Rhino Heavy Duty - MITSUBISHI Triton ML

6 Track location.

- a. Locate the track extrusion into the roof channel and against the rib running through.
- b. The extrusion with end cap must sit up against the rear roof trim.

a.

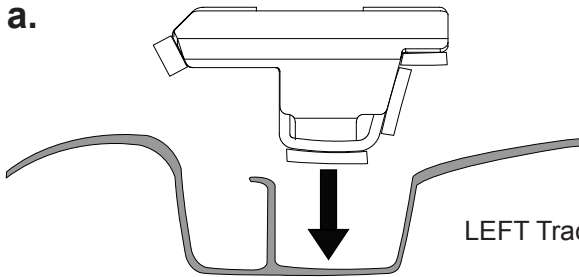

LEFT Track extrusion viewed from rear.

b.

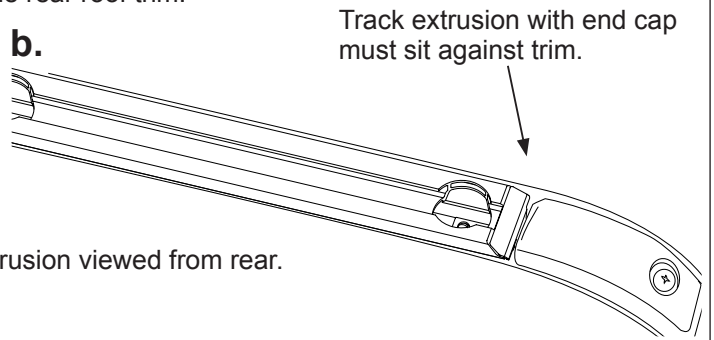

Track extrusion with end cap must sit against trim.

7



Left side shown.

Spot drill holes.

Assistance in holding the track extrusion by a second person is recommended. Have the assistant locate and keep downward pressure on the track while you spot all the holes. Using a 5mm bit spot drill the holes starting from the rear. Maintain track alignment by pulling against the rib in the roof channel.

CAUTION



Wiring loom runs within roof cavity directly below drill locations in Step 8.

Use of a drill stop is required to eliminate the chance of contacting the wires within the roof cavity. The fitter needs to ensure that a drill stop is used and adjusted correctly (as detailed in Step 8) before proceeding.

8



Adjust the drill bit and drill stop in the drill chuck so that you start with 3mm length. Then adjust the drill bit again to 4mm length once you have started drilling. If the hole has not been established, adjust the drill bit to 5mm (max). This is to ensure that you do not damage the wiring loom directly underneath the sheetmetal.

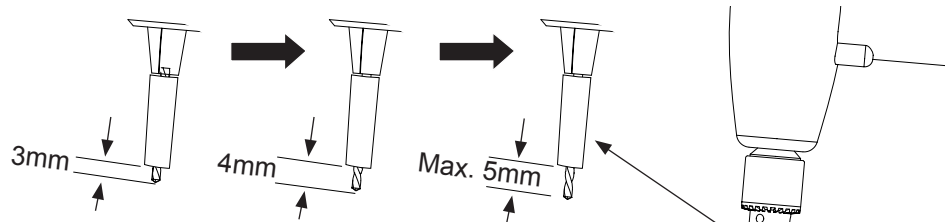

Maintain 90° to the surface being drilled.



Check interior light is still functioning. This will indicate no damage to wiring

9

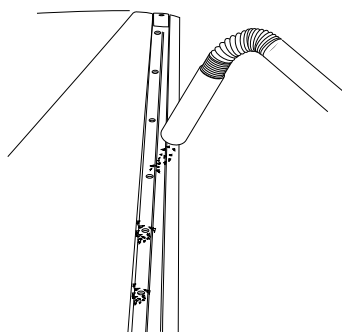

Vacuum swarf.

Use a vacuum cleaner to remove swarf from the roof. This will minimise swarf entering the hole and avoid scratching.



Rhino Heavy Duty - MITSUBISHI Triton ML

10

STEP 1.

STEP 2.

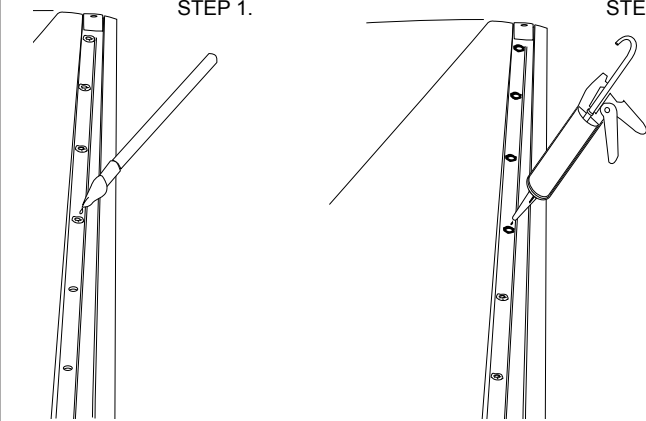

Apply sealer.

STEP 1. Apply a liberal amount of cold galvanizing solution to the inside and surrounds of all holes. Allow cold galvanizing solution to touch dry, ten minutes or so, **STEP 2.** Apply a liberal amount of Selley's Butyl Mastic sealer in and around each hole.

11 Fasten track.

Peel off the white backing strip from the under side foam. Locate front end cap. Place track over holes, check for alignment before riveting. Start riveting front to rear while keeping the track against the thin rib in the roof channel.

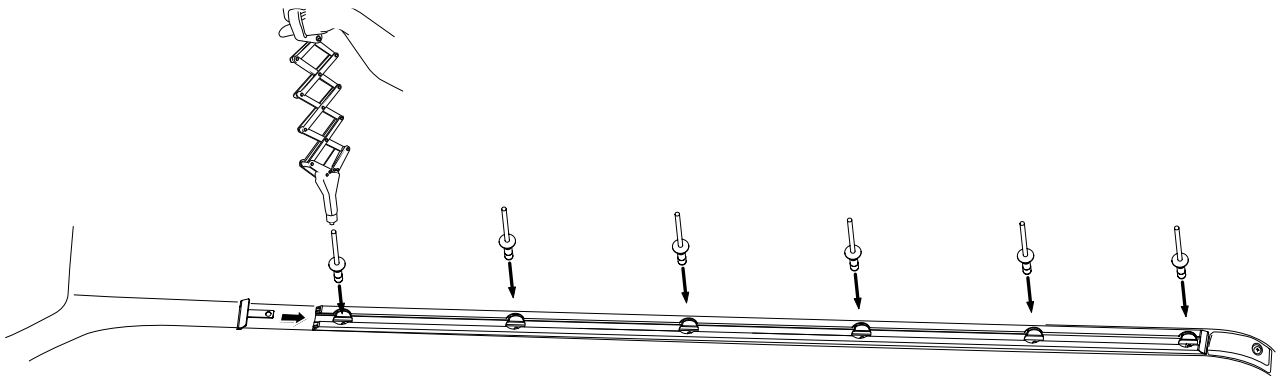

12 Cut and re-fit roof trim.

Measure and mark a distance of 1200mm from the rear of the roof trim. Lay the roof trim over the roof channel with the front tucked in at the base of the windscreen. Check this on your installation. Use a hacksaw to cut through the trim. Re-fit the roof trim.

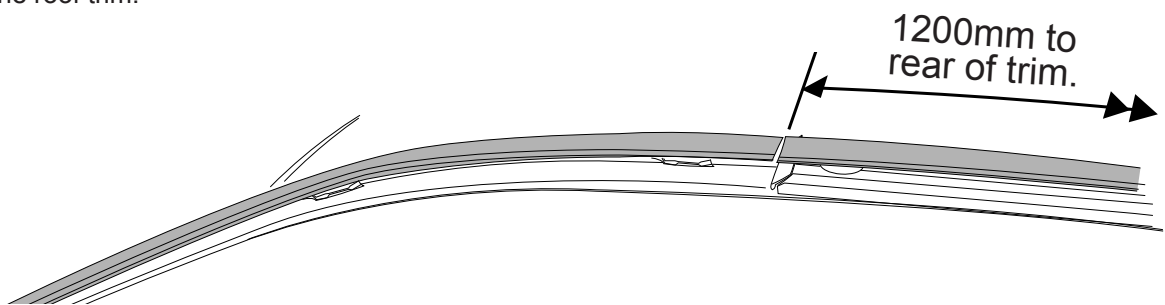

13

Front cross bar/leg has the swivel adaptor fitted.

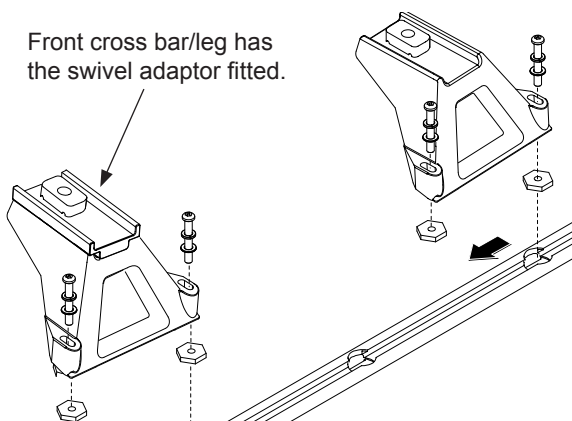

Attach leg.

Unscrew the Brass hex nuts from the RLTF leg. Place the Hex nuts from each RLTF leg into the cut outs of the track and slide along to desired position. The leg with the swivel adaptor goes at the front. The legs will be secured in place after the cross bars are attached.



Rhino Heavy Duty - MITSUBISHI Triton ML

14

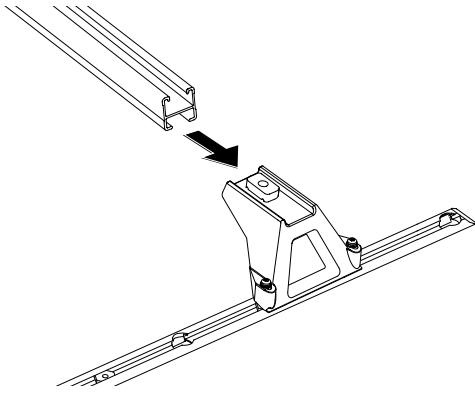

Attach cross bar.

Slide cross bar onto leg and locate with the M10 channel nut. Finger tighten so that the channel nut turns to locate across the cross bar. Leave loose as the legs will require final adjustment and tightening later.

Channel nut must locate across the bar.

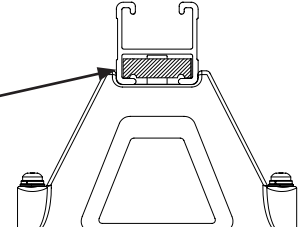

15

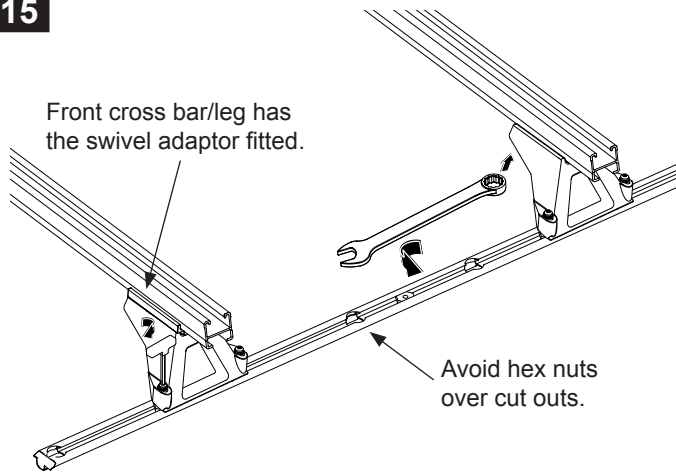

Front cross bar/leg has the swivel adaptor fitted.

Avoid hex nuts over cut outs.

Tension cross bar and legs.

Front RLTF Leg uses the swivel adaptor under the cross bar. Locate the RLTF legs Parallel across the vehicle onto the tracks. Fasten M6 security screws into the brass hex nuts. Do not place hex nuts over cut outs in the track.

16

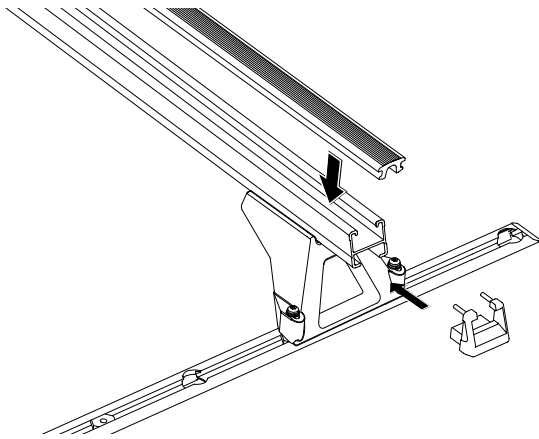

Fit cross bar rubber and end caps.

Insert the cross bar rubber buffer strip into the top of the cross bar. Insert the end caps into the ends of the crossbar, a rubber mallet may be required to fit the end caps.

17

Check over hang.

Use a tape measure to check the cross bar over hang is equal on both sides, re-adjust if required. Tighten the M6 screws to **3-4N/m**. Tighten the M10 cross bar bolts to **5-6 N/m**.

