



**CONTROLLED**

# RHINO-RACK

## RLCP38 RLCP39 Leg Kit - Jeep JK Pioneer Fit

Note: Instructions cover both 2Dr and 4Dr Jeep Jk Models.

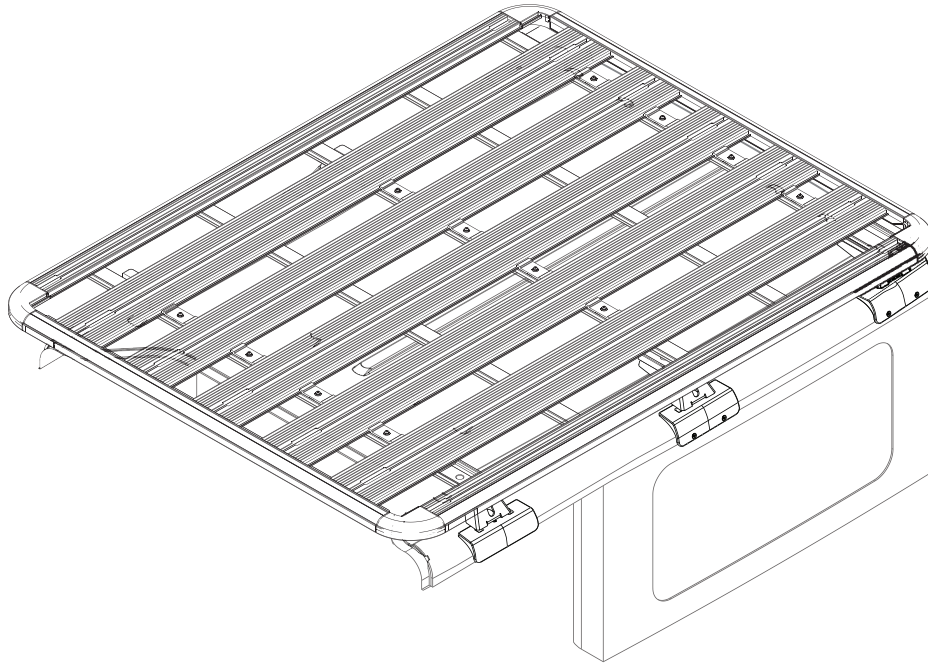

### Important Information

**Max: 120kg (264lbs) - Three Crossbars. Max: 100 (220lbs) - Two Crossbars.** Time: 30 mins.

Read through instructions before installation. If you are unsure or have any questions, refer to the dealer or place of purchase.

**Recommendations:**

It is essential that all bolt connections be checked after driving a short distance when you first install your crossbars. Bolt connections should be checked again at regular intervals (once a week is enough, depending on road conditions, usage, loads and distances travelled). You should also check the crossbars each time they are refitted. Make sure to fasten your load securely. Please ensure that all loads are evenly distributed and that the centre of gravity is kept as low as possible. Use non stretch ropes.

**Please remove crossbars when putting vehicle through an automatic car wash.**

**Load Ratings:**

Maximum permissible load is 120kg (264lbs) for three crossbars including the weight of the crossbars, 7.5kg (16lbs) for three bars and 5kg (11lbs) for two bars. When crossbars are to be used in off-road conditions, please build a safety factor of 1.5 into this load limit for off-road use, three crossbars = **80kg (176lbs)** and two crossbars = **66kg (145lbs)**. Although the crossbars are tested and approved to AS1235-2000, Off road conditions can be much more rigorous. However, increasing the number of crossbars does not increase the vehicles maximum permissible roof loading.

**Note for Dealers and Fitters: This is a two person installation. The removal of the hard top requires assistance.** It is your responsibility to ensure instructions are given to the end user or client.

Rhino-Rack  
3 Pike Street, Rydalmere,  
NSW 2116, Australia.  
(Ph) (02) 9638 4744  
(Fax) (02) 9638 4822

Document No: R812  
Prepared By: Kayle Everett  
Authorised By: Chris Murty

Fit Time: 1 hour  
Issue No: 03  
Issue Date: 08/10/2015

These instructions remain the property of Rhino-Rack Australia Pty. Ltd. and may not be used or changed for any other purpose than intended.



# RLCP38, RLCP39

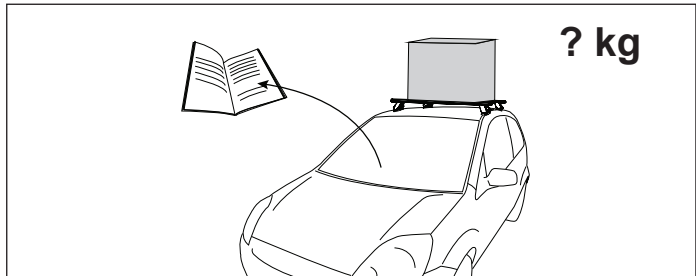
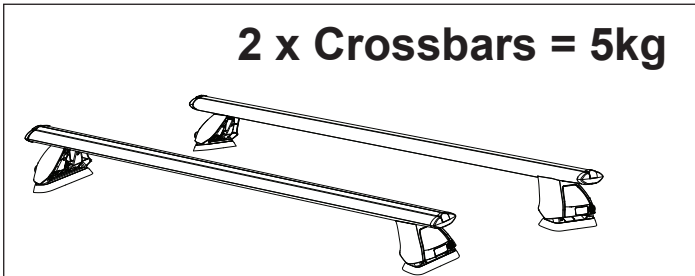
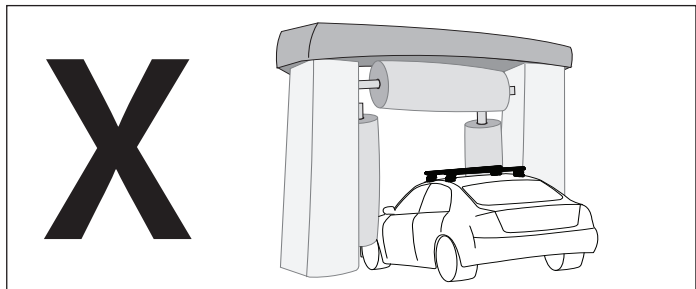
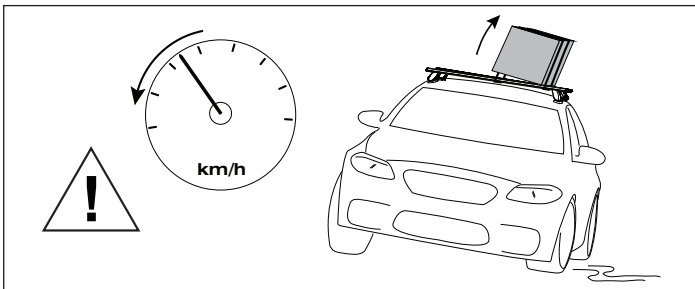
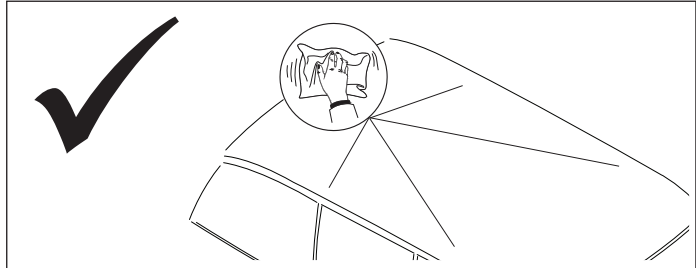
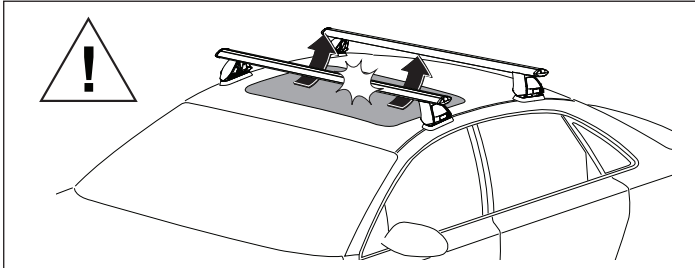
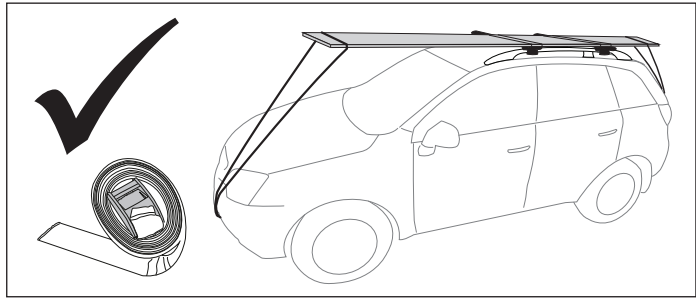
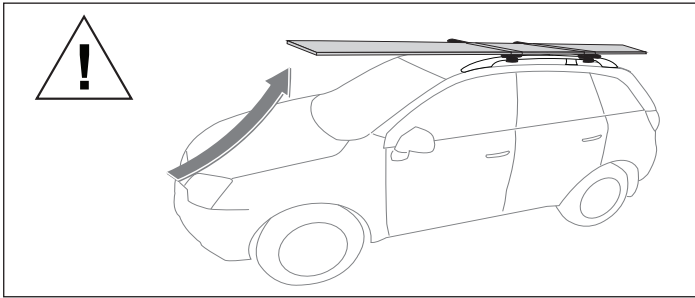

When these roof racks are to be used on a vehicle that is driven off sealed roads the maximum load rating must be divided by 1.5. Remember to subtract the weight of the roof racks to determine your maximum permissible load capacity.

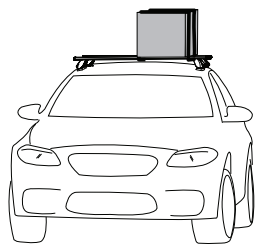

3 bars 120kg (264lbs)	=	3 bars 80 kg (176lbs)
2 bars 100kg (220lbs) load rating (Urban road)		2 bars 66kg (145lbs) load rating (Off road)
Load rating not taking into account crossbar weight - 5kg		

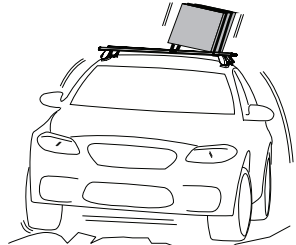

## WARNING! Important Load Carrying Instructions

With utility vehicles, the cabin and the canopy move independently. Roof racks and vehicle can be damaged if the item transported is rigidly fixed at points on both the cabin and canopy. Instead, rigidly fix to either the cabin roof racks or the canopy roof racks.

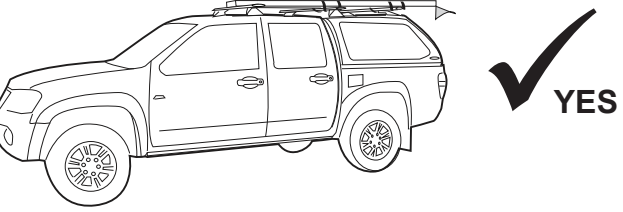
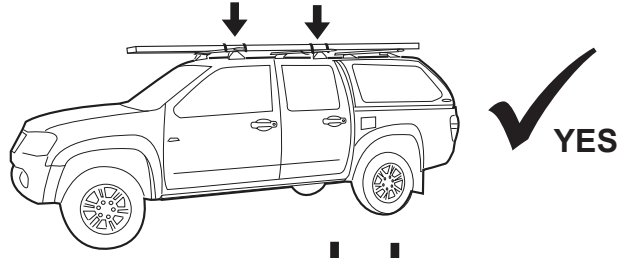
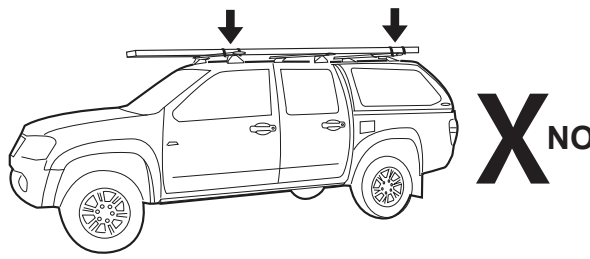



# RLCP38, RLCP39

## Parts List

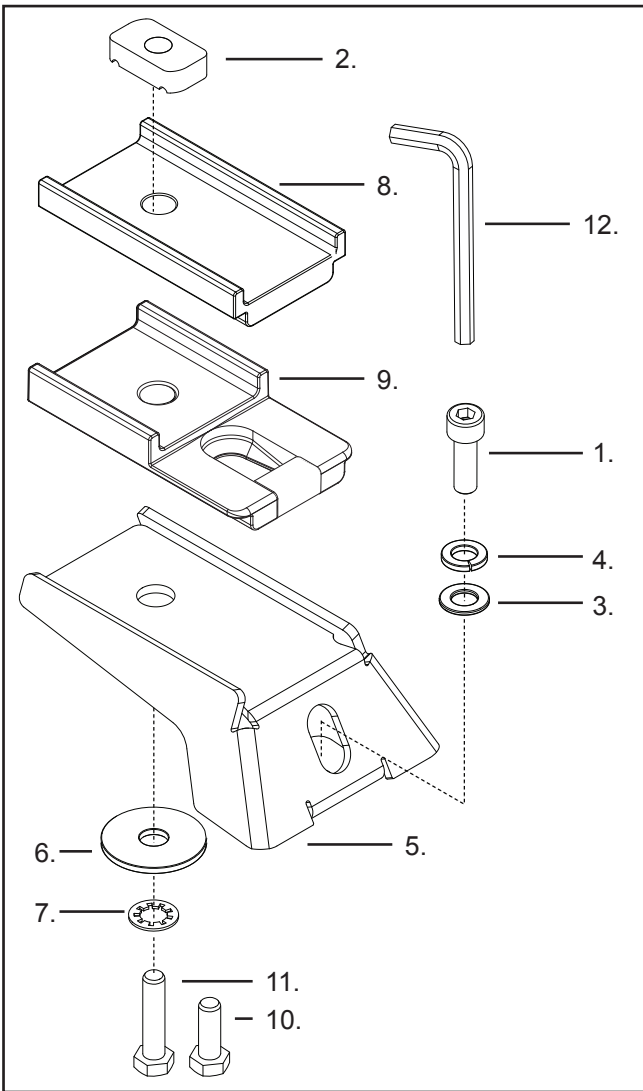

Parts List		RLCP38	RLCP39	Part No.
1	M6x20 Socket HD Cap-screw	6	4	B054
2	M10 Channel Nut	6	4	N024
3	M6x12.5mm Flat Washer	6	4	W003
4	M6 Spring Washer	6	4	W004
5	Metal RLCP Legs	6	4	CA1394
6	M10x38x2.5 Flat Washer	6	4	W022
7	M10 Internal S/Proof Washer	6	4	W021
8	Nylon 10mm Spacer	4	2	M016
9	Pioneer Leg Height Spacer	4	2	M609
10	M10x35mm Hex Setscrew	4	4	B079
11	M10x45mm Hex Setscrew	2	-	B080
12	5mm Security Screw	1	1	H021
13	Instructions	1	1	R812

**Note:**

The following instructions provide information relating to the RLCP38/RLCP39 fitting a Pioneer Platform, Tray or Tradie Tray to the Jeep JK Backbone.

These kits are sold separately.

**Tools Required:**

13mm Socket Wrench

5mm Allen Key (provided)

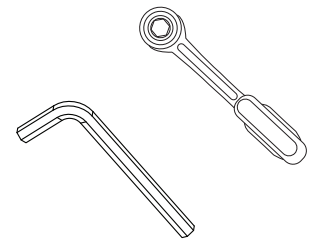

**1** Using the M6 Capscrew, M6 Spring and Flat Washers, fix Metal RLCP Legs to the Back Bone. With the allen key provided tighten legs in place to 3-4Nm.

Note: Remove the ends of the Pioneer Leg Height Spacers carefully with a saw or blade.

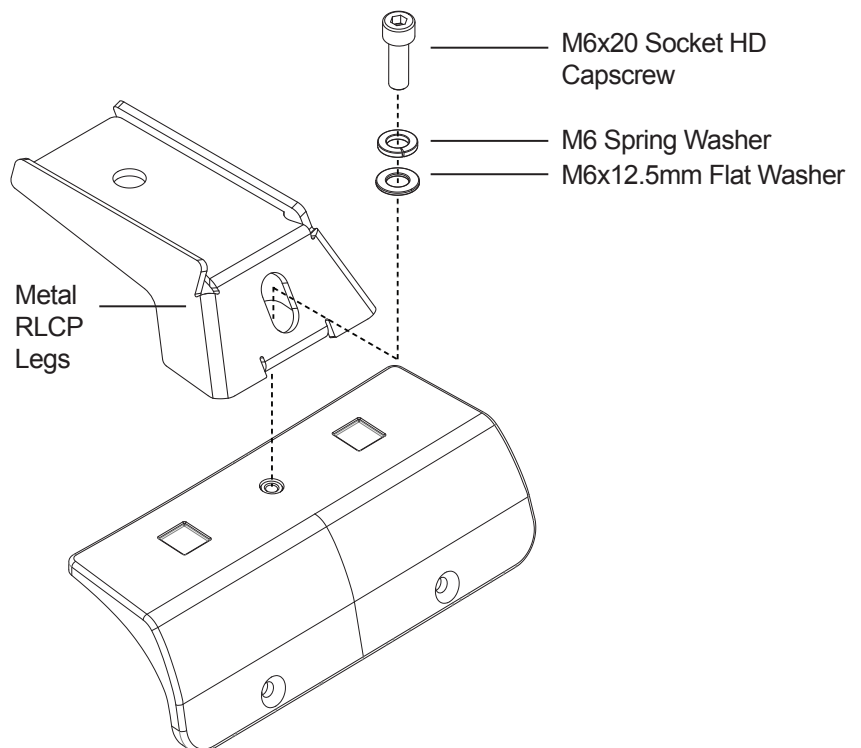
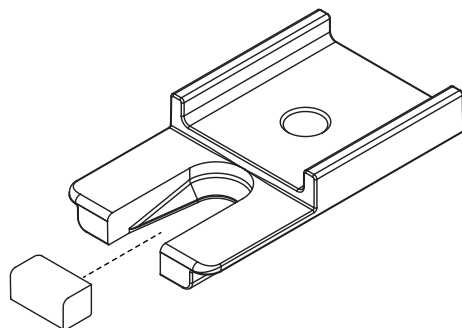



# RLCP38, RLCP39

## Pioneer Tray Fit - Jeep JK Wrangler

**RLCP38 4Dr JK Pioneer Wrangler setup. Note: Pioneer as separate.**

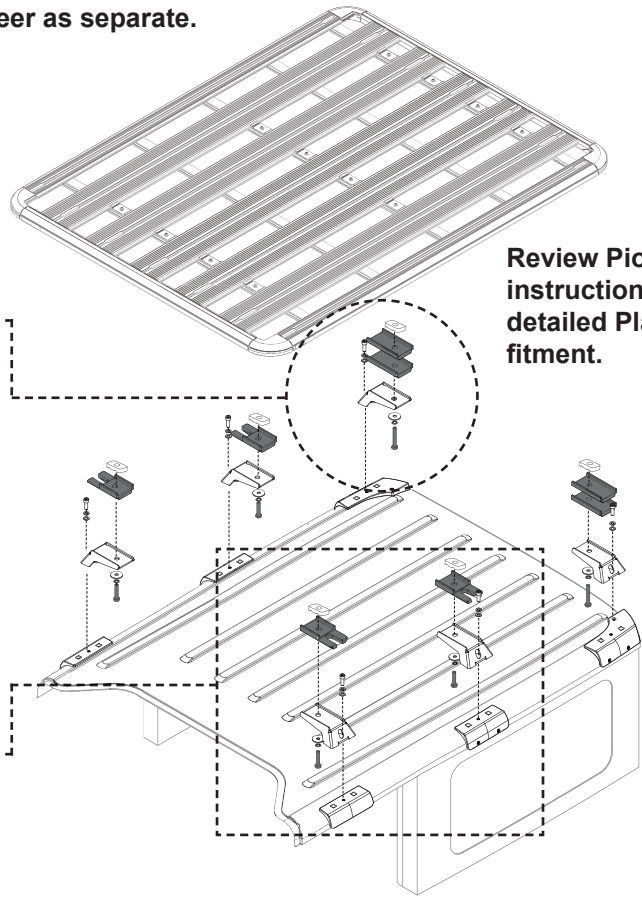
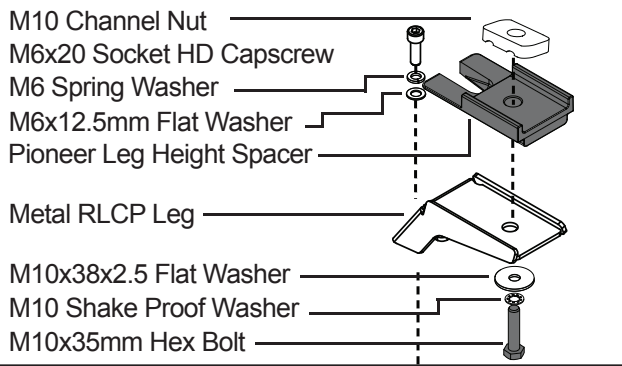
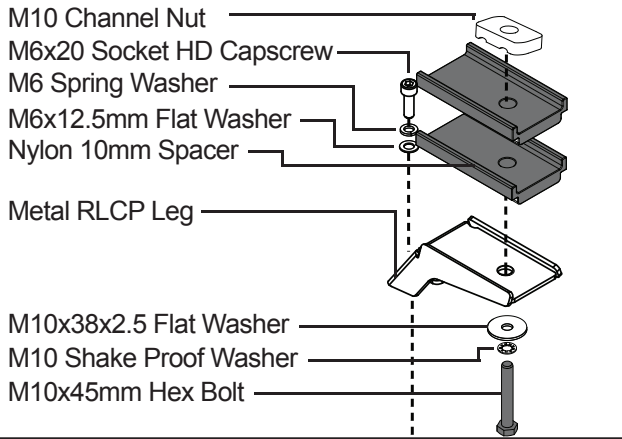

**RLCP39 2Dr JK Pioneer Wrangler setup. Note: Pioneer as separate.**

